

ABR2500W - ABR2510W

PRV : 50 - 1000 Volts

Io : 25 Amperes

FEATURES :

- * High case dielectric strength
- * High surge current capability
- * High reliability
- * Low reverse current
- * Low forward voltage drop
- * Ideal for printed circuit board
- * **Pb / RoHS Free**

MECHANICAL DATA :

- * Case : Molded plastic with heatsink integrally mounted in the bridge encapsulation
- * Epoxy : UL94V-O rate flame retardant
- * Terminals : Plated lead solderable per MIL-STD-202, Method 208 guaranteed
- * Polarity : Polarity symbols marked on case
- * Mounting position : Bolt down on heat-sink with silicone thermal compound between bridge and mounting surface for maximum heat transfer efficiency
- * Weight : 15.95 grams

AVALANCHE BRIDGE RECTIFIERS

BR50W

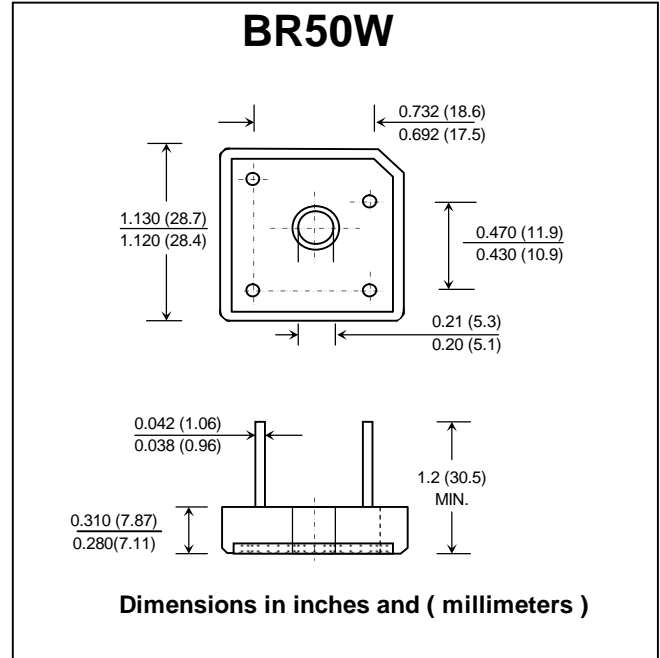

Dimensions in inches and (millimeters)

MAXIMUM RATINGS AND ELECTRICAL CHARACTERISTICS

Rating at 25 °C ambient temperature unless otherwise specified.
Single phase, half wave, 60 Hz, resistive or inductive load.
For capacitive load, derate current by 20%.

RATING	SYMBOL	ABR 2500W	ABR 2501W	ABR 2502W	ABR 2504W	ABR 2506W	ABR 2508W	ABR 2510W	UNIT
Maximum Recurrent Peak Reverse Voltage	V _{RRM}	50	100	200	400	600	800	1000	V
Maximum RMS Voltage	V _{RMS}	35	70	140	280	420	560	700	V
Maximum DC Blocking Voltage	V _{DC}	50	100	200	400	600	800	1000	V
Minimum Avalanche Breakdown Voltage at 100 μA	V _{BO(min.)}	100	150	250	450	700	900	1100	V
Maximum Avalanche Breakdown Voltage at 100 μA	V _{BO(max.)}	550	600	700	900	1150	1350	1550	V
Maximum Average Forward Current T _c = 50°C	I _{F(AV)}	25							A
Peak Forward Surge Current Single half sine wave Superimposed on rated load (JEDEC Method)	I _{FSM}	300							A
Rating for fusing at (t < 8.3 ms.)	I ² t	375							A ² S
Maximum Forward Voltage per Diode at I _F = 12.5 A	V _F	1.1							V
Maximum DC Reverse Current T _a = 25 °C at Rated DC Blocking Voltage T _a = 100 °C	I _R	10							μA
	I _{R(H)}	200							μA
Typical Thermal Resistance (Note 1)	R _{θJC}	1.45							°C/W
Operating Junction Temperature Range	T _J	- 50 to + 150							°C
Storage Temperature Range	T _{STG}	- 50 to + 150							°C

Note :

1) Thermal resistance from Junction to case with units mounted on a 5" x 6" x 4.9" (12.8cm x 15.2cm x 12.4 cm) Al. plate.

RATING AND CHARACTERISTIC CURVES (ABR2500W - ABR2510W)

FIG.1 - DERATING CURVE FOR OUTPUT RECTIFIED CURRENT

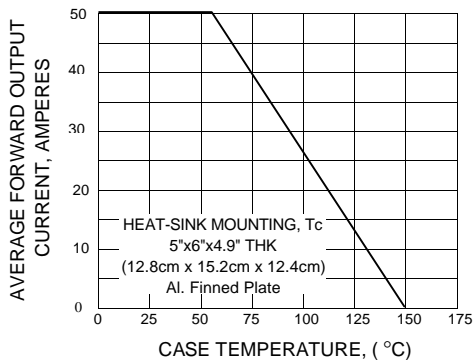

FIG.2 - MAXIMUM NON-REPETITIVE PEAK FORWARD SURGE CURRENT

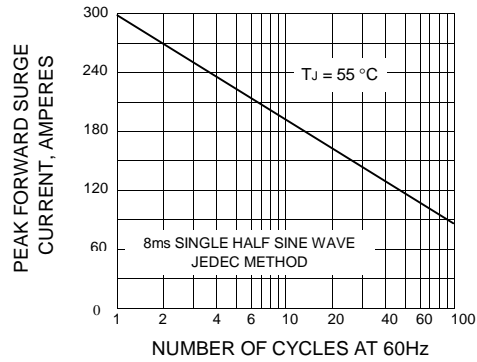

FIG.3 - TYPICAL FORWARD CHARACTERISTICS PER DIODE

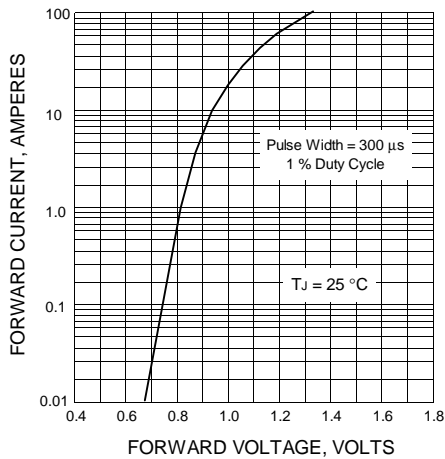

FIG.4 - TYPICAL REVERSE CHARACTERISTICS

